



Competition Act – Recent Developments and Case Studies

13th February 2016

Prohibition of certain agreements / Abuse of Dominant Position

Section 3

Anti-Competitive Agreements

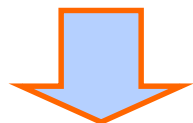

Agreements in relation to goods / services which have an 'Appreciable Adverse Effect on Competition ("**AAEC**")' in India shall be void

Section 4

Abuse of Dominant Position

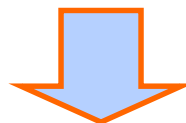

Specified practices prohibited if carried out by dominant enterprises which results into abuse of dominance position

Section 5&6

Combinations

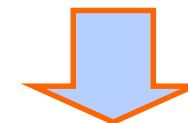

Combination which causes or is likely to cause an **AAEC** within the relevant market in India shall be void

Section 5 & 6 - Combinations

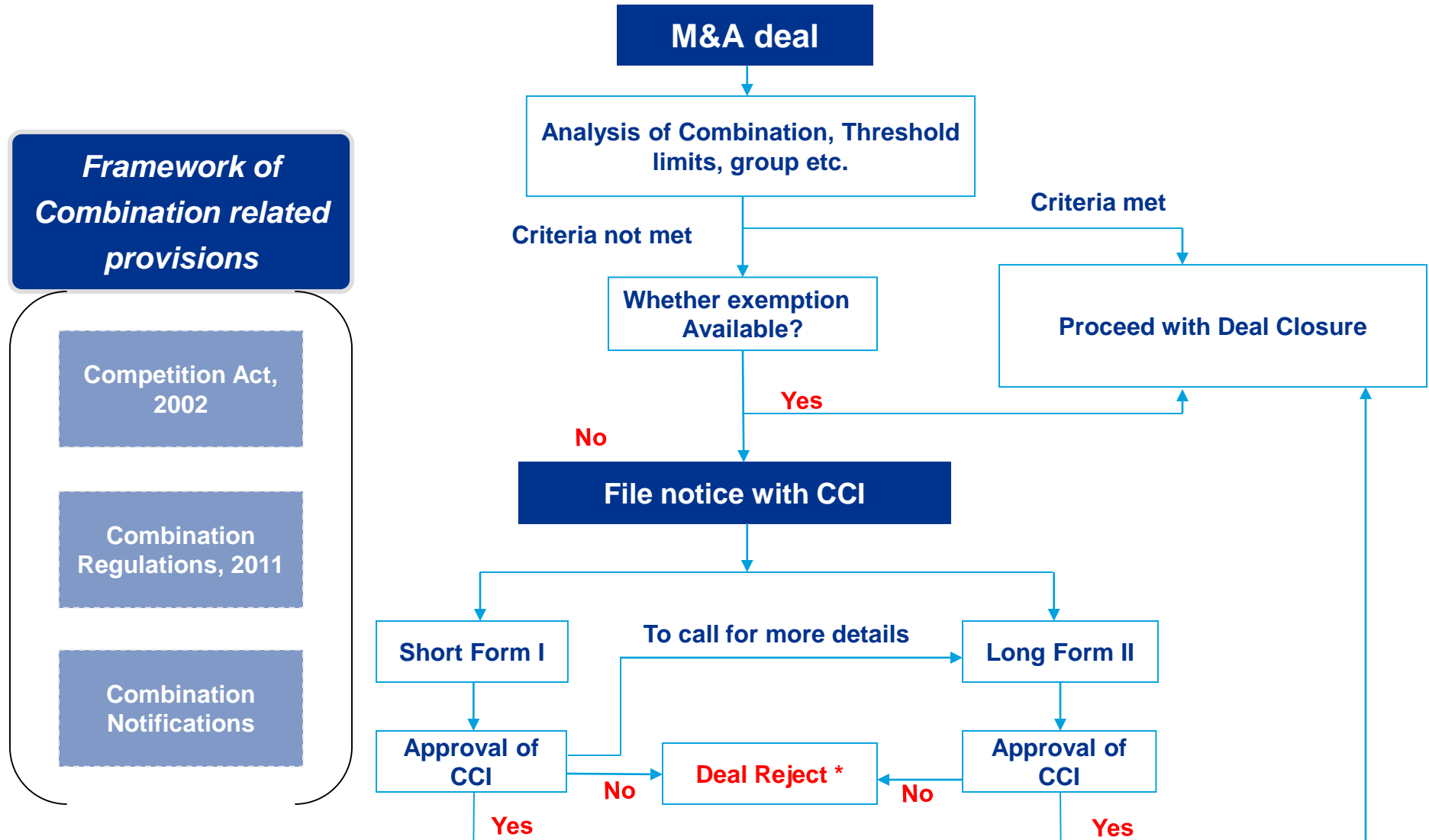

* Grounds for rejection - If combination causes AAE or modifications to Combination sought by CCI are not carried out, etc.



Process Overview

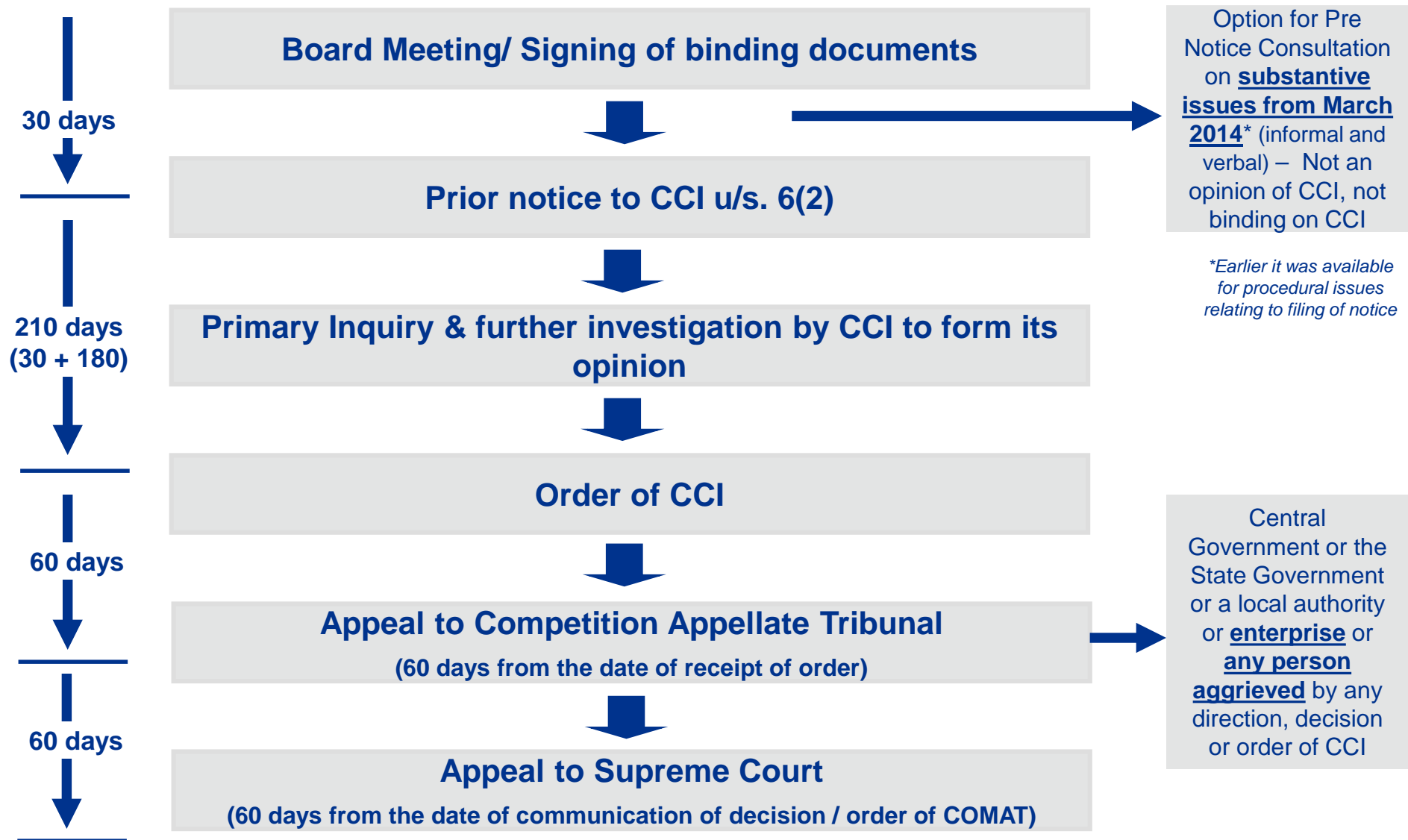

Threshold limits

Combination

Sec 5: Combination

Acquisition of one or more enterprises by one or more persons or merger / amalgamation of enterprises if it involves:

- a) Any acquisition of **control, shares, voting rights or assets**;
- b) **Acquiring of control** over an enterprise if the person already has direct/ indirect control over another enterprise in similar product/service; and
- c) **Merger or amalgamation**

The above shall be regarded as “combinations” under Competition Act if they meet the threshold requirements and would require pre-approval from CCI unless exempted

CCI filing mandatory within 30 days u/s. 6(2) of Competition Act for all combinations on and after 1 June 2011

Penalty leviable upon failure to give notice to CCI, which may extend to 1% of Total Turnover or Assets of such combination, whichever is higher

CCI has powers to regulate combinations which causes or likely to cause an AAEC within the relevant market in India

Key Definitions

‘Acquisition’ means, directly or indirectly, acquiring or agreeing to acquire -

- shares, voting rights or assets of any enterprise; or
- control over management or control over assets of any enterprise

‘Group’ means two or more enterprises which, **directly or indirectly**, are in a position to –

- exercise **26%** or more of **voting rights** in the other enterprise*;
- appoint more than **50%** of **Board of directors** in the other enterprise; or
- control the management or affairs** of the other enterprise

**Definition of Group has been relaxed in public interest vide Notification S.O. 481(E) dated 4 March 2011 - ‘Group’ exercising less than 50% of voting rights in other enterprise exempted from the provisions of section 5 for a period of 5 years*

‘Enterprise’ (key extract of definition)

- Means person engaged in activity of production /sale of goods, providing services or holding of / dealing in securities either directly or through one or more of its units / divisions or subsidiaries

‘Control’ includes controlling the affairs or management by –

- one or more enterprises, either jointly or singly, over another enterprise or group;
- one or more groups, either jointly or singly, over another group or enterprise

Key Definitions

‘Value of Assets’ shall be determined by taking book value of assets as per last audited books of accounts of the enterprise of **financial year immediately preceding the financial year in which merger falls** and

- reduced by depreciation;
- to include brand value, value of goodwill, copyright, patent, permitted use, collective mark, registered proprietor, registered trademark, registered user, homonymous geographical indication, geographical indications, design or layout design or similar other commercial rights, if any, referred to in Sec. 3(5)

‘Turnover’ includes value of sale of goods or services

Whether intangibles not recorded in books of accounts to be taken?

Turnover for which year to be considered – preceding FY or the year of combination?

Whether other / miscellaneous income be considered in Turnover?

Should turnover be considered on Gross or Net of taxes?



Prescribed thresholds for Combinations

Basis	Individual Enterprise		Group of Enterprises	
	In India	In India or outside India	In India	In India or outside India
Total Assets	>Rs. 1,500 cr	>US\$ 0.75 bn (including atleast Rs. 750 cr in India)	>Rs. 6,000 cr	> US\$ 3 bn (including atleast Rs. 750 cr in India)
Turnover	>Rs. 4,500 cr	> US\$ 2.25 bn (including atleast Rs. 2,250 cr in India)	>Rs. 18,000 cr	> US\$ 9 bn (including atleast Rs. 2,250 cr in India)

Anyone of the above threshold to be satisfied!!

Power to Central Government, in consultation with CCI, to modify the value of assets & turnover every 2 years

Case Study – Thresholds vs. Market share of the Product

1

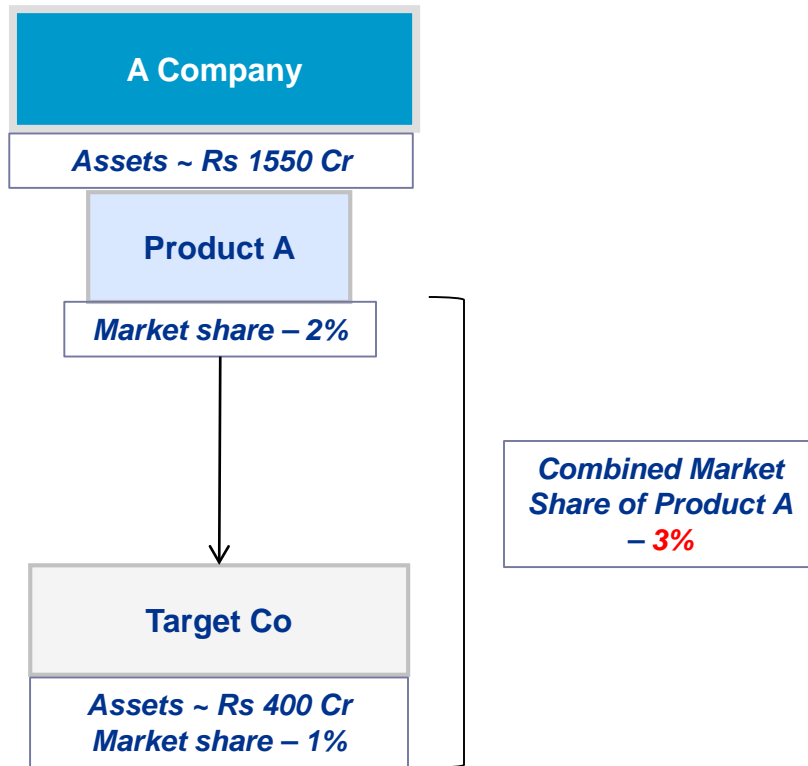

Whether notice to CCI u/s. 6(2) required?

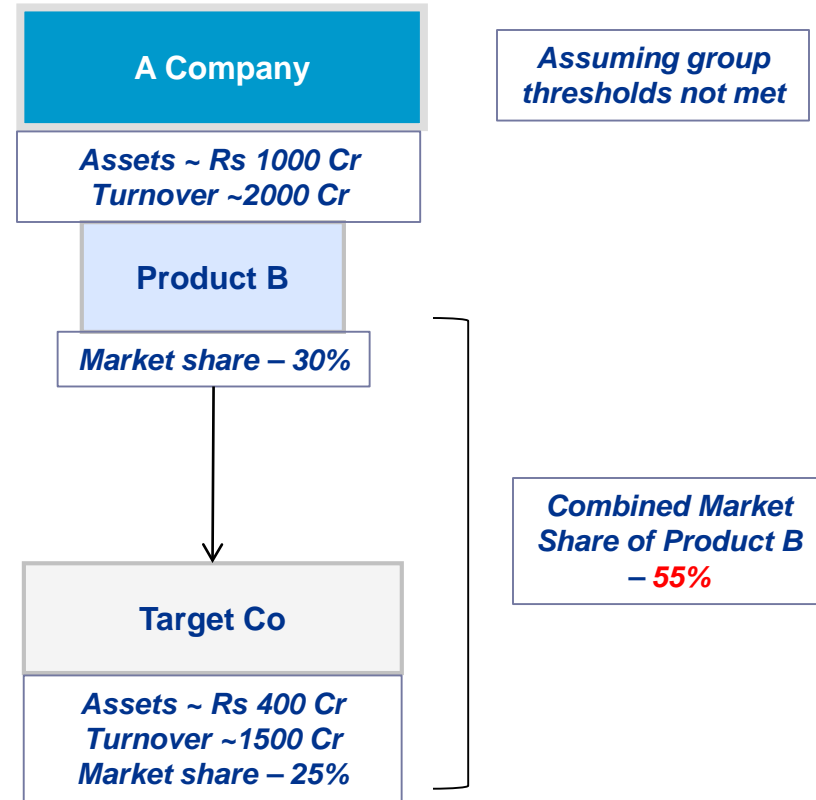

Whether notice to CCI u/s. 6(2) required?



Case Study - Group

2

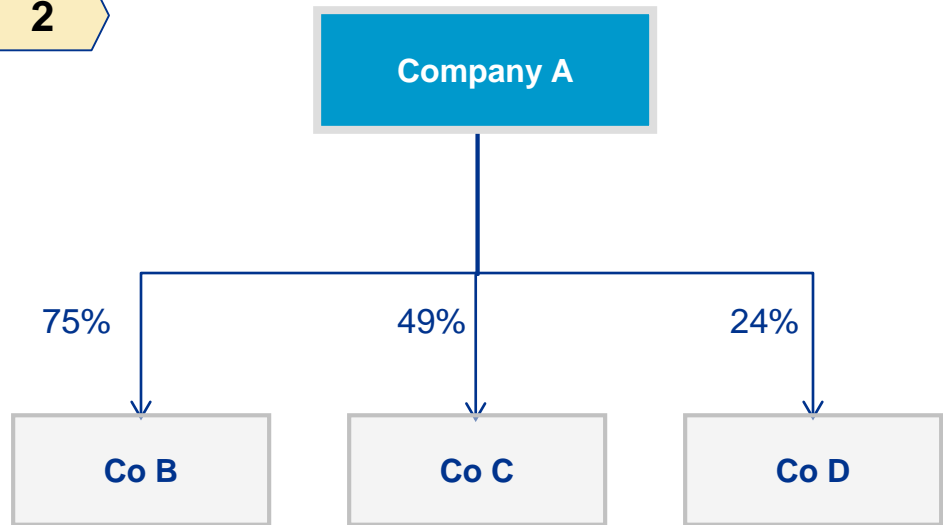

Which companies be included for "Group"?

3

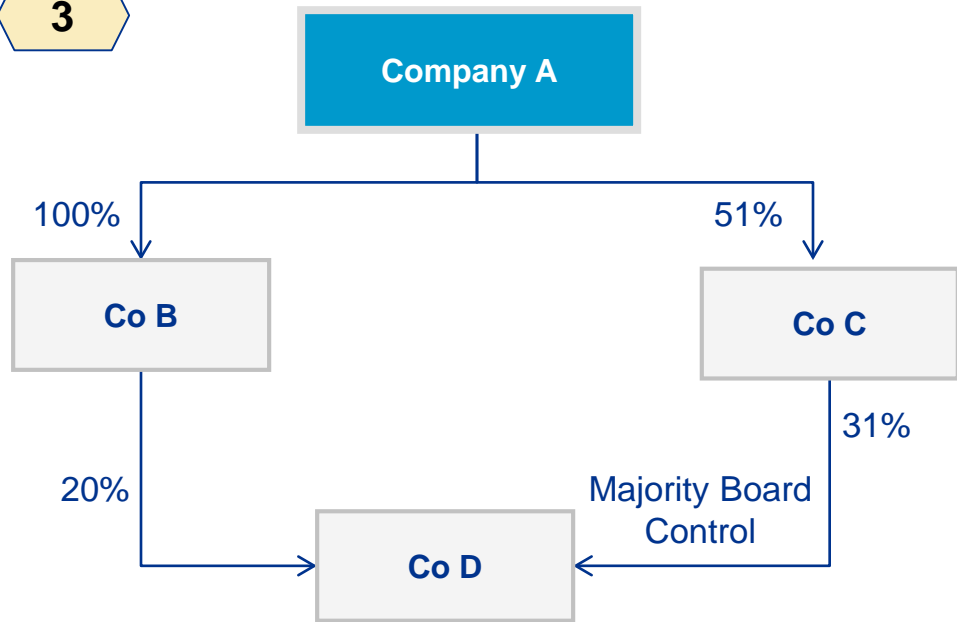

Which companies be included for "Group"?

What if Co A holds 49% in Co C?

Case Study - Group

X, Y and Z are individual

4

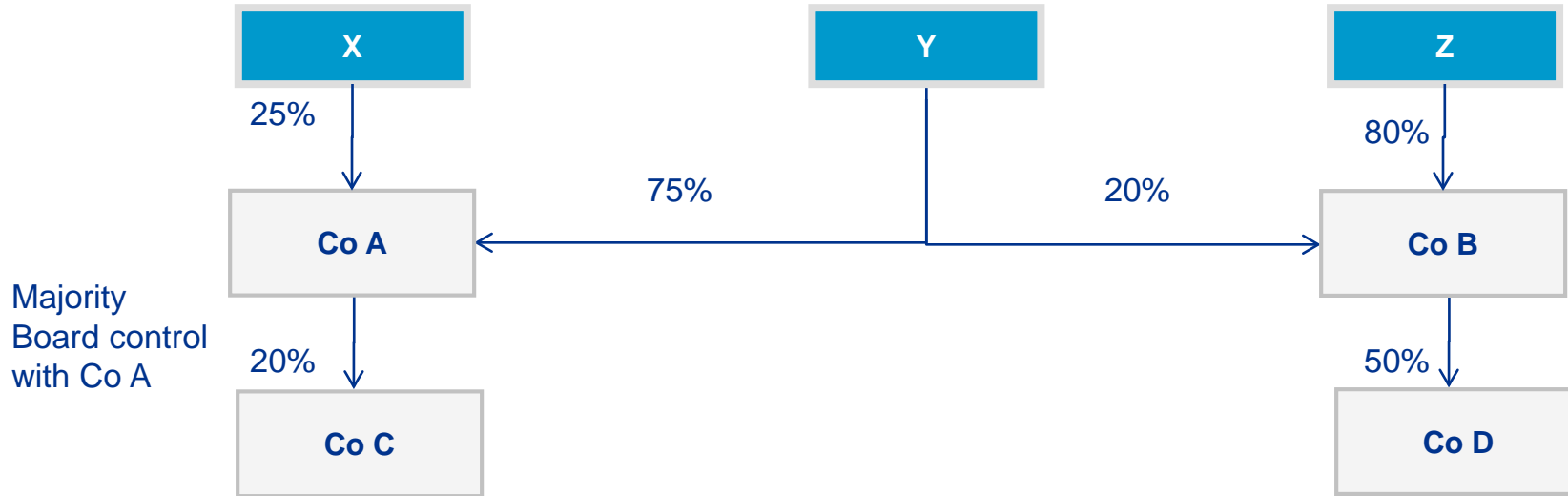

How many “group” are formed ?

What happens if X, Y & Z are related and exercise control ?

Case Study - Group

ABC & Z are part of different group

5

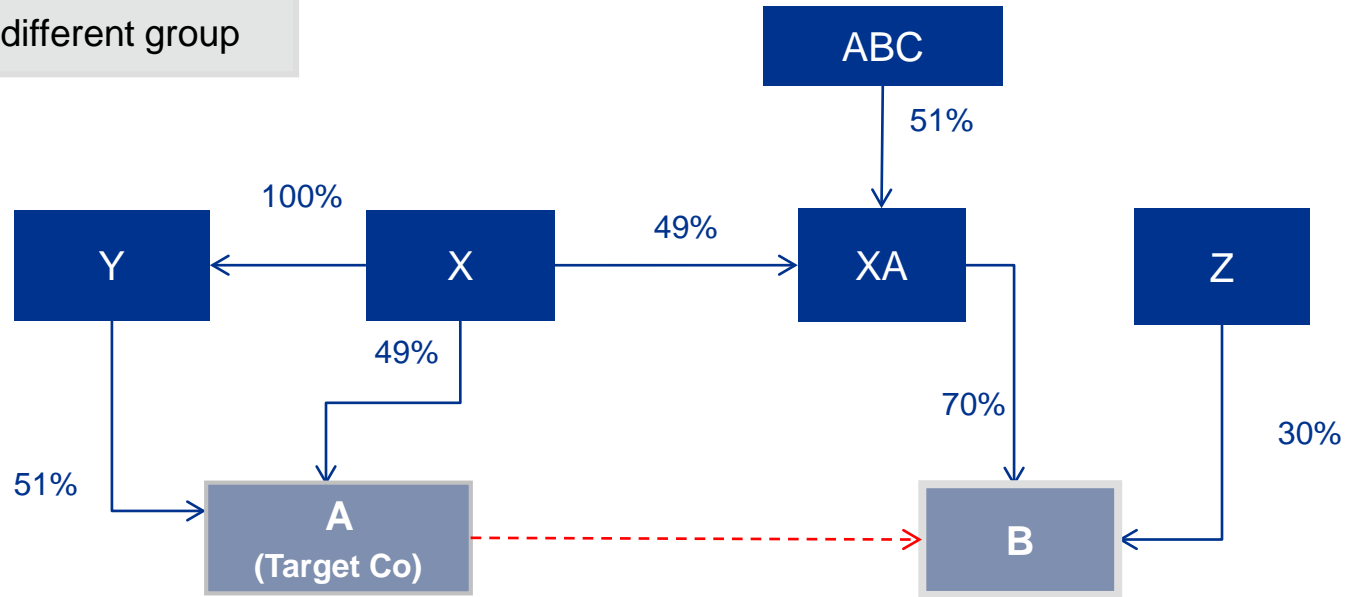

Whether X and XA are part of the same group?

Whether B is a part of 3 Groups
i.e. X Group, ABC Group and Z Group?

Case Study - Thresholds

6

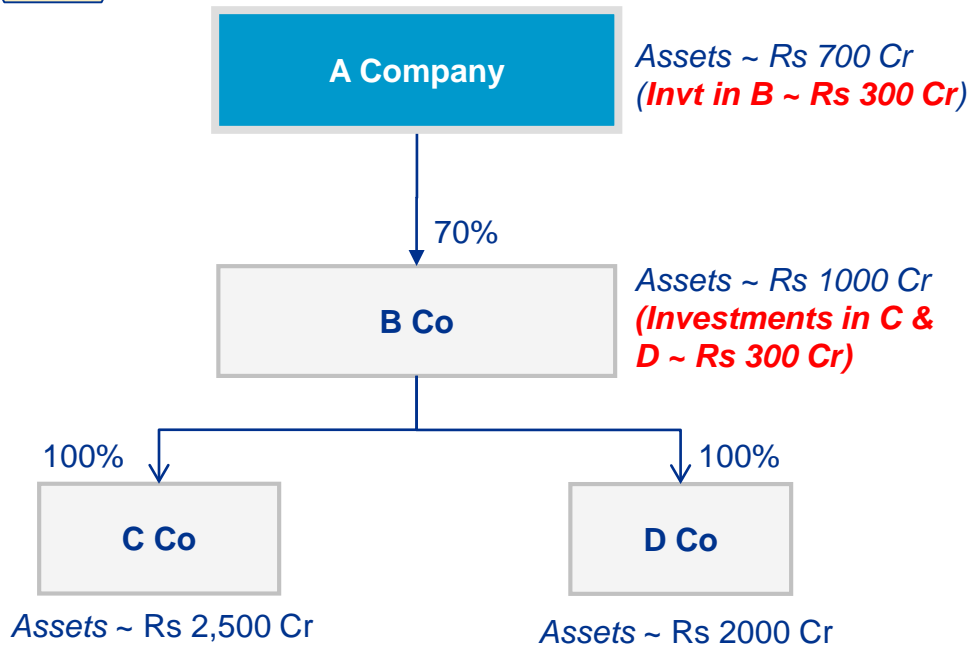

What is the 'value of assets' of the Group - Rs. 6,200 cr or 5,600 cr?

7

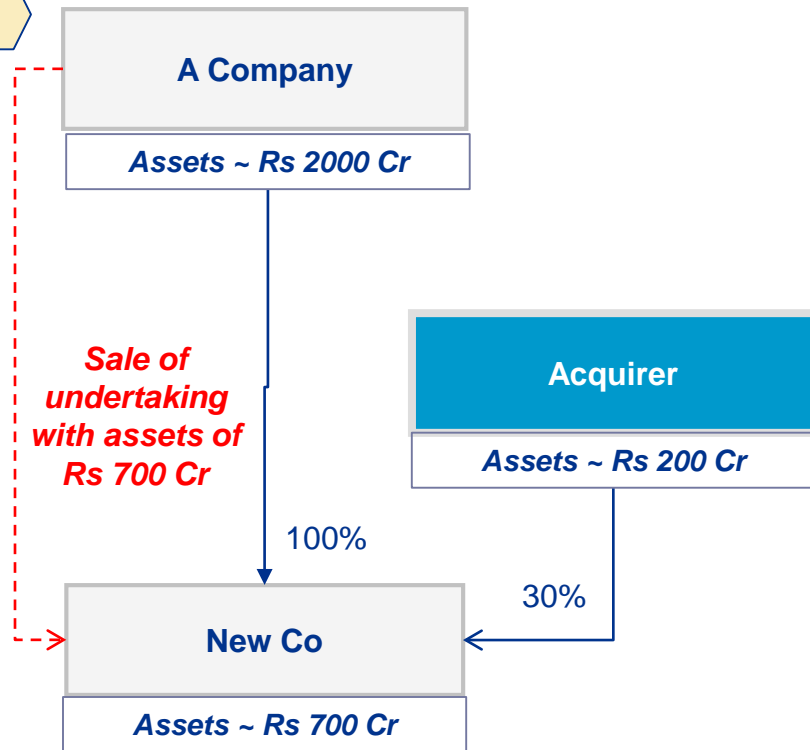

Does acquisition of 30% stake in New Co require CCI notification

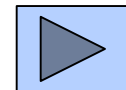

1

Case Study - Thresholds

8

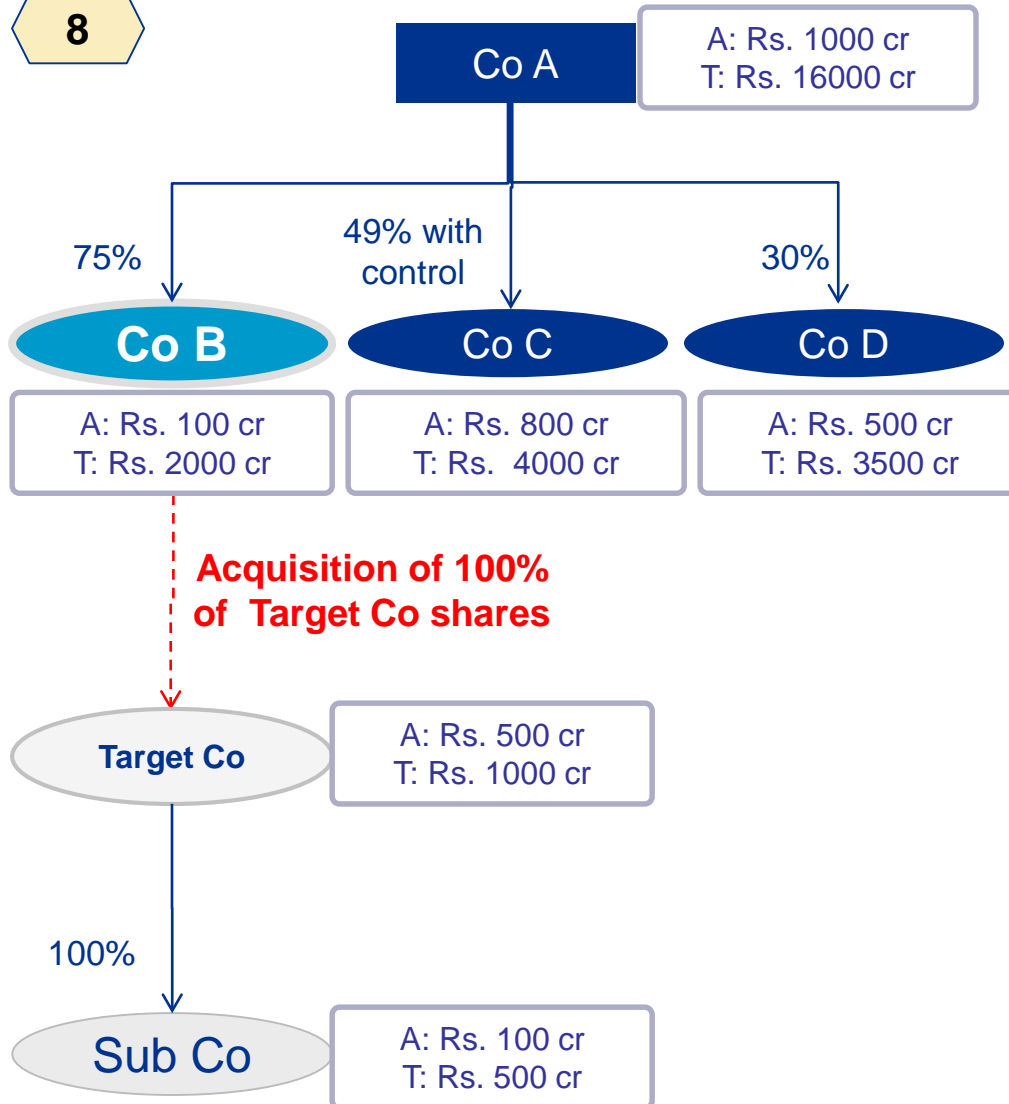

Party test

Name of Co	Assets (Rs. cr)	Turnover (Rs. cr)
Co B	100	2,000
Target Co	500	1,000
Target Sub Co ?	100	500
Total	700	3,500

Group test

Name of Co	Assets (Rs. cr)	Turnover (Rs. cr)
Co A	1,000	16,000
Co B	100	2,000
Co C	800	4,000
Target Co	500	1,000
Target Sub Co	100	500
Total	2,500	23,500

Case Study - Thresholds

9

X, Y, Z are relatives and control Co A & Co B

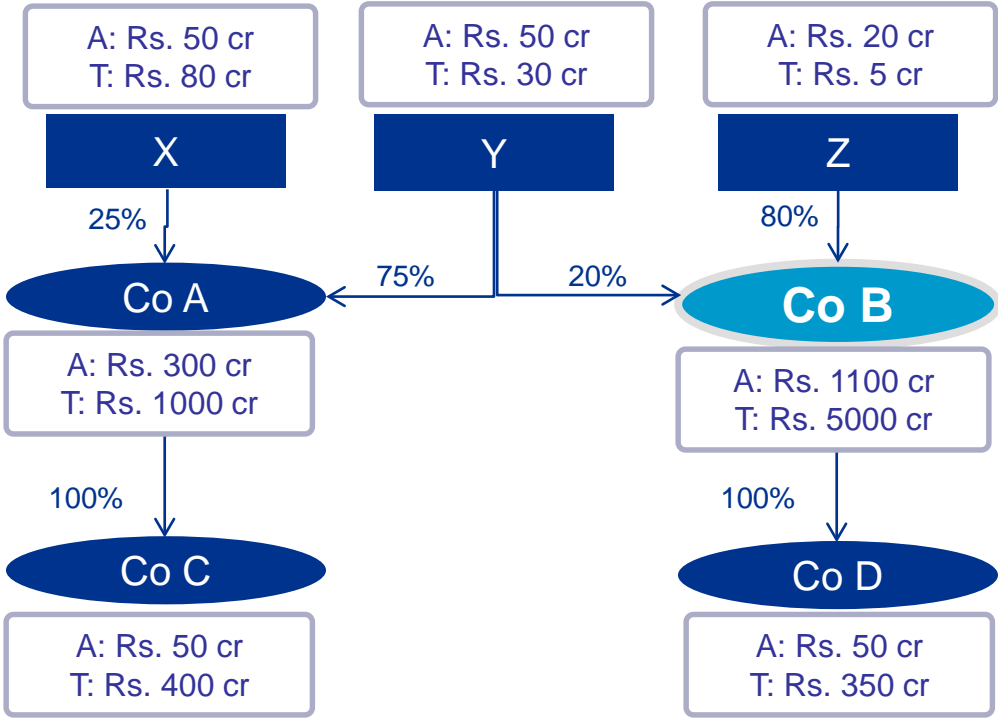

Group test

Name of Entity	Assets (Rs. cr)	Turnover (Rs. cr)
X ?	50	80
Y ?	50	30
Z	20	5
Co A?	300	1,000
Co B	1,100	5,000
Co C?	50	400
Co D	50	350
Target Co	500	4,000
Total	2,120	10,865

Party test

Name of Co	Assets (Rs. cr)	Turnover (Rs. cr)
Co B	1,100	5,000
Target Co	500	4,000
Total	1,600	9,000

Case Study – Combination - Demerger

10

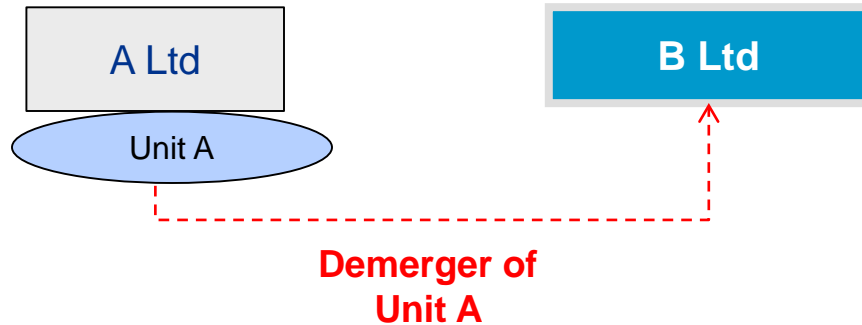

Transaction: Demerger of Unit A to B Ltd through a court approved scheme

Whether notice to CCI required?

Whether covered under clause 5(a) or 5(c)?

What would be the binding document for demerger?

Case Study – Combination - Slump Sale

11

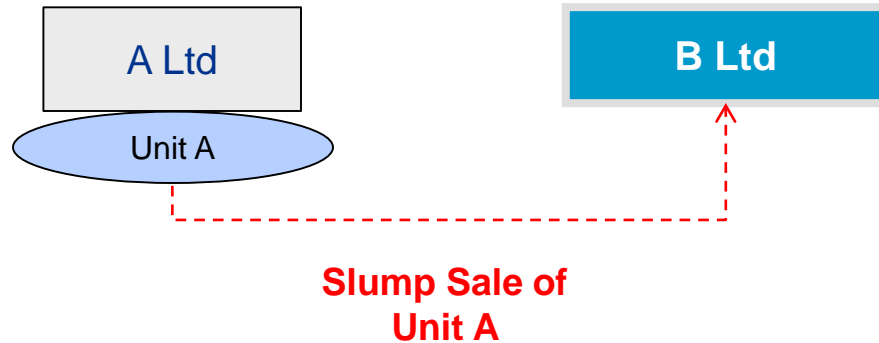

Transaction: Transfer of Unit A to B Ltd through slump sale

Whether notice to CCI required?

Whether covered under clause 5(a) or 5(c)?

Criteria to be tested for undertaking or target as a whole?

If slump sale under the Scheme of Arrangement under section 391 to 394 of the Cos Act, 1956?

Case Study – Combination at overseas parent level

12

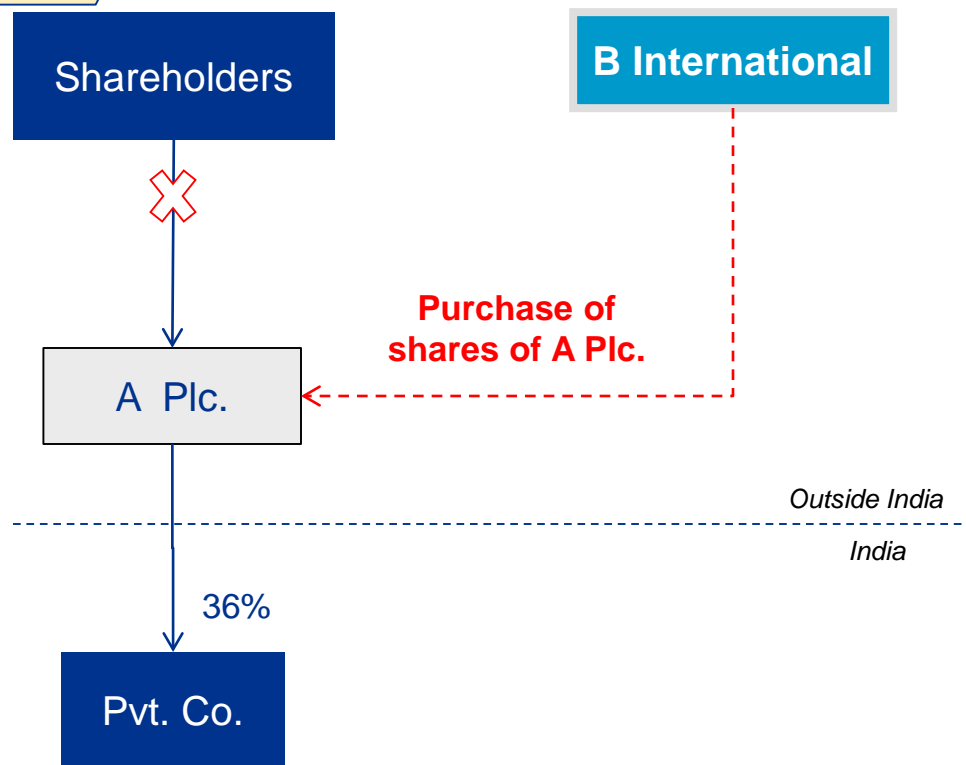

Transaction: Acquisition of shares of A Plc. by B International outside India

Facts

- B International and A Plc. are companies registered outside India
- A Plc. holds 36% shares in Pvt Co.

Whether CCI approval required?

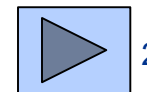

Whether CCI approval required for merger of A Plc. with B International?

Case Study - Joint ventures

13

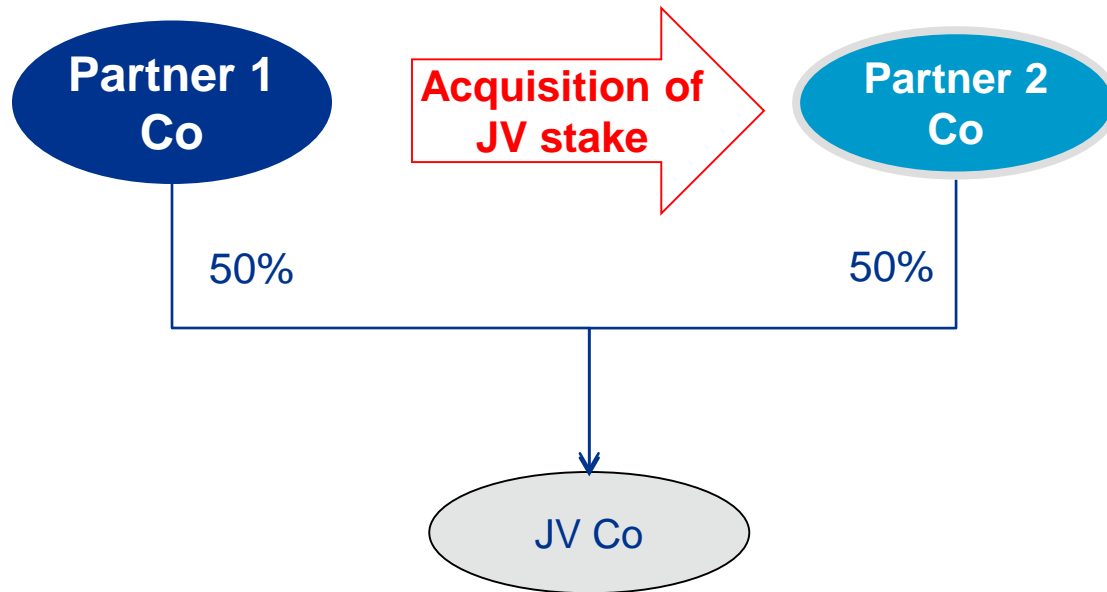

Transaction: Partner 1 desires to exit JV and his entire stake is proposed to be bought by Partner 2

Would Partner 1 Co and Partner 2 Co qualify as 'Group'?

Would notice to CCI be required?

Case Study - Shares

14

‘**Shares**’ means shares in the share capital of company **carrying voting rights** and includes -

- Any security which **entitles the holder to receive shares with voting rights**;
- Stock except where a distinction between stock and share is expressed or implied

Whether notice would need to be given to CCI on signing of the investment agreement for subscribing to below instruments?

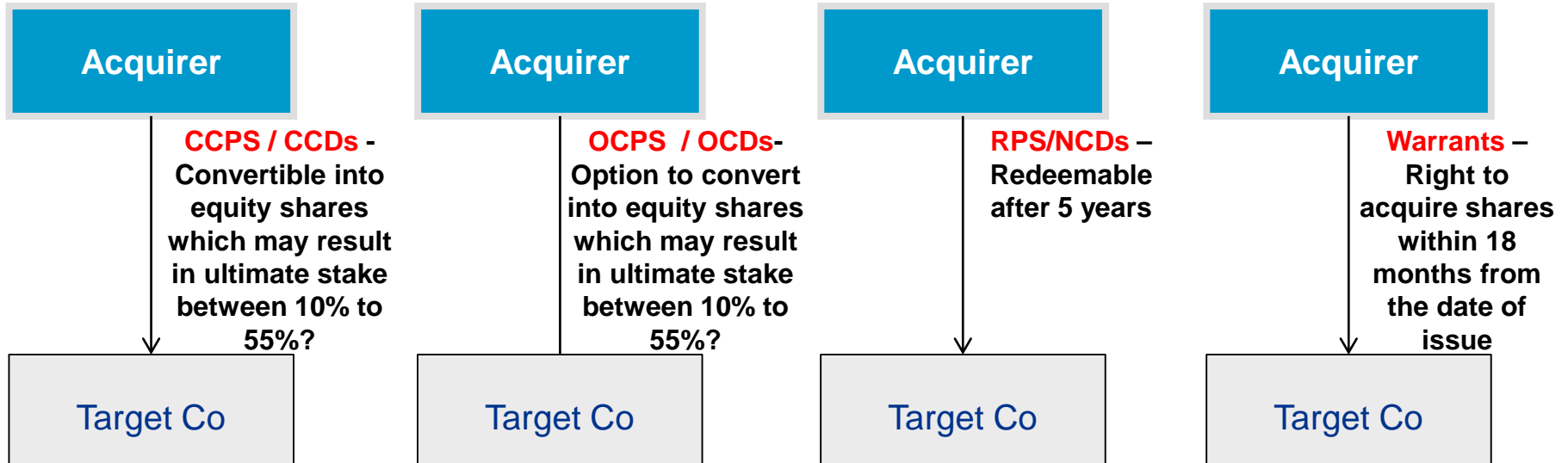

Exemptions:

- a) Target Based Exemption**
- b) Schedule I of Combination Regulations , 2011**
- c) Section 6(4)/(5) of the Competition Act , 2002**
- d) Exemption for Banking Companies**

Target Based Exemption

Enterprise, whose control, shares, voting rights or assets are being acquired has **assets of the value of not more than Rs 250 crs in India** **OR** **turnover of not more than Rs 750 crs in India** is exempted from the provisions of section 5 for a period of 5 years - Notification S.O. 482 dt 4 Mar 2011 (as amended)

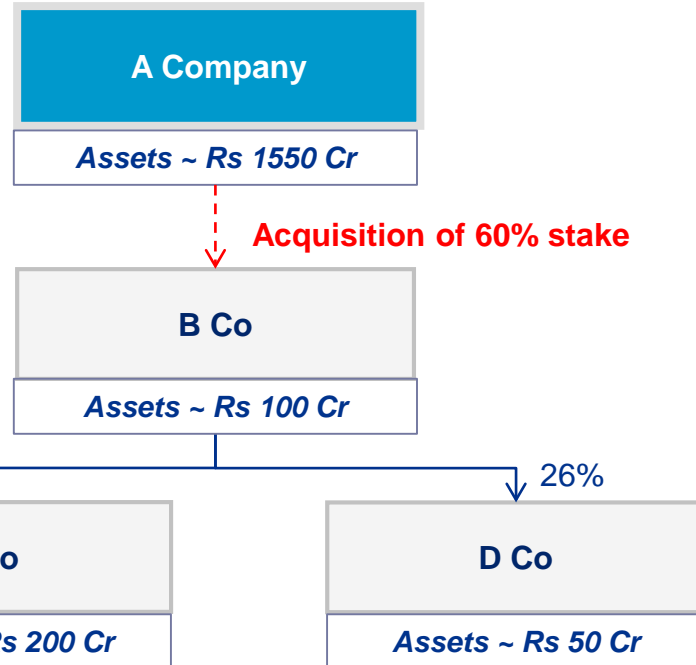

Whether Target based exemption applicable to target enterprise or target Group for party test?

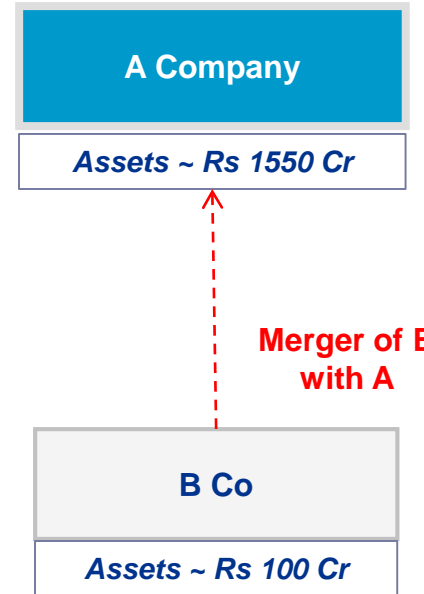

Whether target based exemption available?

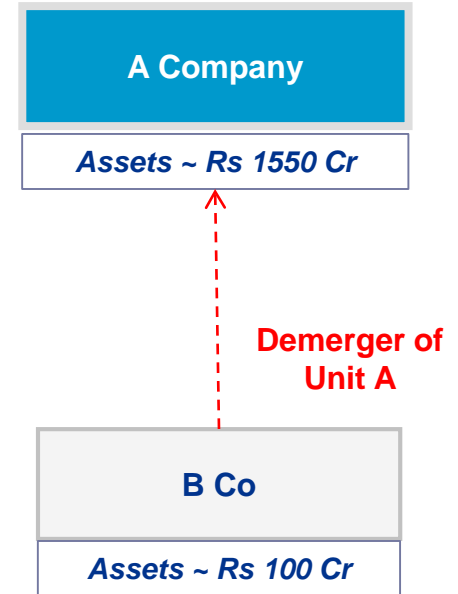

Whether target based exemption available?

Schedule I – Notice need not normally be filed

Transactions not ordinarily likely to result in an appreciable adverse effect on competition

▪ Acquisition of shares or voting rights -

– **Clause 1**- for section 5(a) - solely as an investment or in ordinary course of business with post acquisition stake less than 25% (directly or indirectly), **not leading** to acquisition of control

- The following explanation has been inserted to Clause 1 under Schedule I of The Competition Commission of India (Procedure in regard to the transaction of business relating to combinations) Regulations, 2011 pursuant to [CCI (Procedure in regard to the transaction of business relating to combinations) Amendment Regulations, 2016, notified on 7th January, 2016] :

The acquisition of less than 10% of the total shares or voting rights of an enterprise shall be treated as **solely as an investment**:

- Provided that in relation to the said acquisition

(A) the Acquirer has ability to exercise only such rights that are exercisable by the ordinary shareholders of the enterprise; and

(B) the Acquirer is not a member of the Board of Directors of the enterprise whose shares or voting rights are being acquired and does not have a right or intention to nominate a director on the Board of Directors and does not intend to participate in the affairs or management of the enterprise.

Schedule I – Notice need not normally be filed

Transactions not ordinarily likely to result in an appreciable adverse effect on competition

▪ Acquisition of shares or voting rights -

- **Clause 1A** of Schedule I exempts the acquirer or its group from filing requirements wherein such acquirer already holds 25% or more shares/voting rights, and wants to acquire additional shares/voting rights but not more than 50% shares/voting rights.
 - The words "not resulting in gross acquisition of more than five percent (5%) of the shares or voting rights of such enterprise in a financial year," have been omitted from Clause 1A under Schedule I pursuant to [CCI Amendment Regulations, 2016, notified on 7th January, 2016]

Schedule I – Notice need not normally be filed

Transactions not ordinarily likely to result in an appreciable adverse effect on competition

- Acquisition of shares or voting rights -
 - **Clause 2-** for section 5(a) - where acquirer already holds 50% or more, **except** if results in transfer from joint control to sole control
 - **Clause 6-** pursuant to bonus issue, stock splits, consolidation of face value of shares, buy-back of shares or subscription to rights issue of shares, **not leading** to acquisition of control
- **Clause 3 - Acquisition of assets** under section 5(a), not directly related to acquirer's business activity or made solely as an investment or in the ordinary course of business, not leading to control, **except** where assets acquired represent substantial business operation of the target enterprise

Schedule I – Notice need not normally be filed

- **Clause 4** - Amended or renewed tender offer where notice to CCI filed prior to such amendment/renewal
- **Clause 5** - Acquisition of stock-in-trade, raw materials, stores and spares, trade receivables and other similar current assets in the ordinary course of business
- **Clause 7** - Securities underwriter or registered stock broker acting on behalf of its clients in the ordinary course of its business
- **Clause 8** - Acquisition of shares or voting rights or assets by one person / enterprise of another enterprise within the same Group, **except** where acquired enterprise is jointly controlled by enterprises that are not part of the same group
- **Clause 9** - A merger or amalgamation of two enterprises where one of the enterprises has more than fifty per cent (50%) shares or voting rights of the other enterprise, and/or merger or amalgamation of enterprises in which more than fifty per cent (50%) shares or voting rights in each of such enterprises are held by enterprise(s) within the same group, **not resulting** in transfer from joint to sole control

Case Study - Acquisition of shares/voting rights

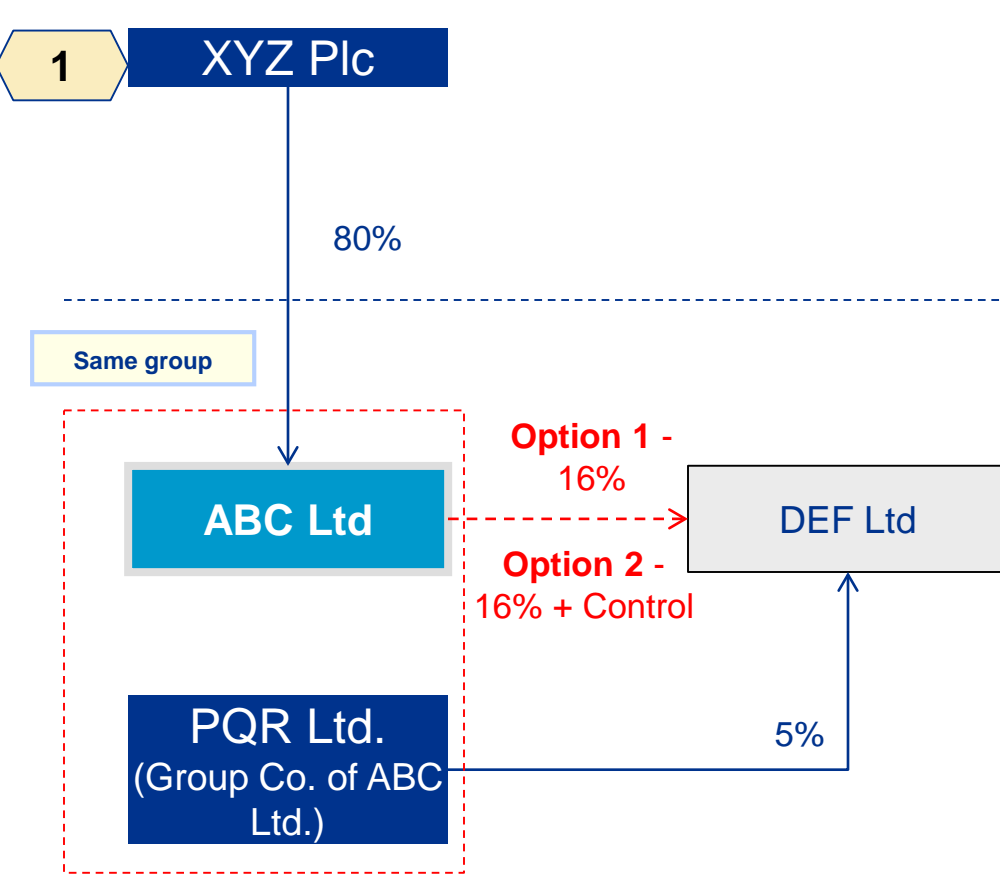

Transaction: ABC Ltd to acquire 16% voting rights in DEF Ltd

Facts:

- PQR Ltd is holding 5% voting rights in DEF Ltd.
- ABC Ltd. and PQR Ltd. are part of the same group

Whether CCI approval required?

Option 1 – If ABC Ltd acquires 16% shares of DEF Ltd.?

Option 2 – If ABC Ltd acquires 16% shares of DEF Ltd. + control?

Case Study - Acquisition of shares/voting rights

2



Transaction: B Ltd. acquires 5% shares in XYZ Ltd

Whether CCI approval required?

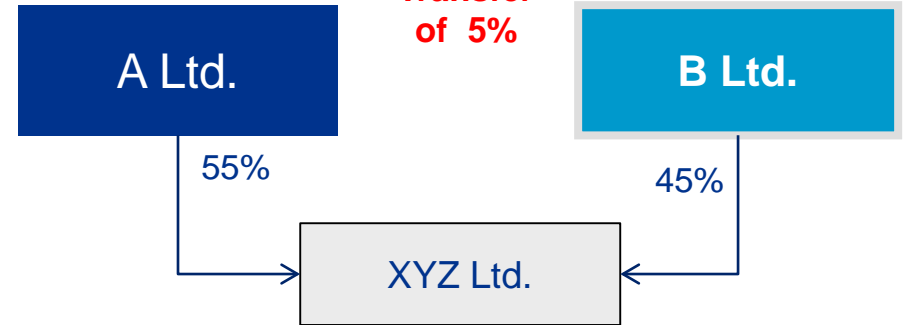

Transaction: B Ltd. acquires 5% shares in XYZ Ltd

Whether CCI approval required?

Case Study - Acquisition of shares/voting rights

3

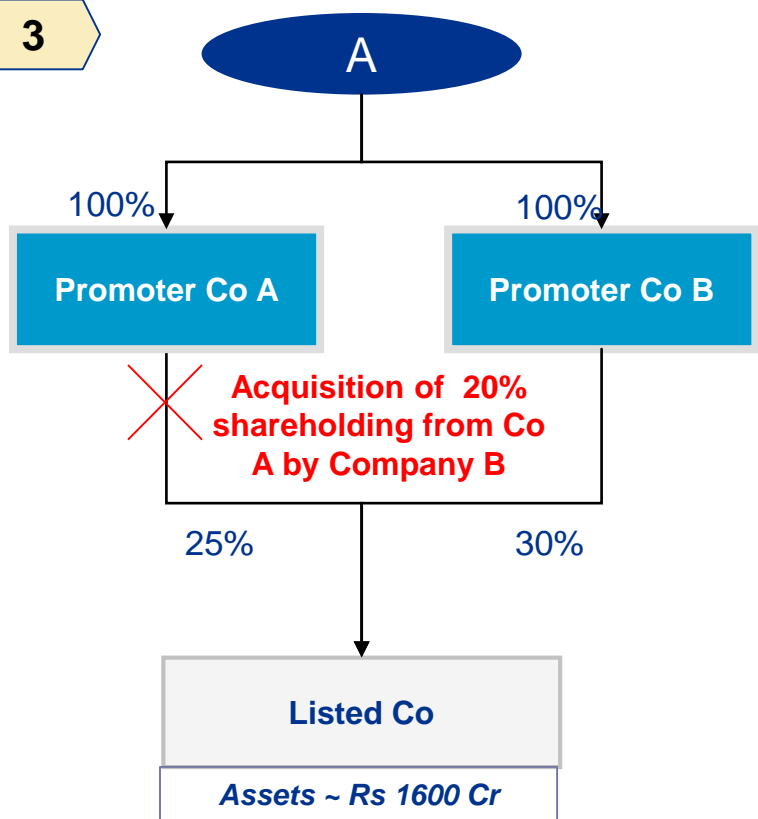

Does the above acquisition qualify for intra group exemption

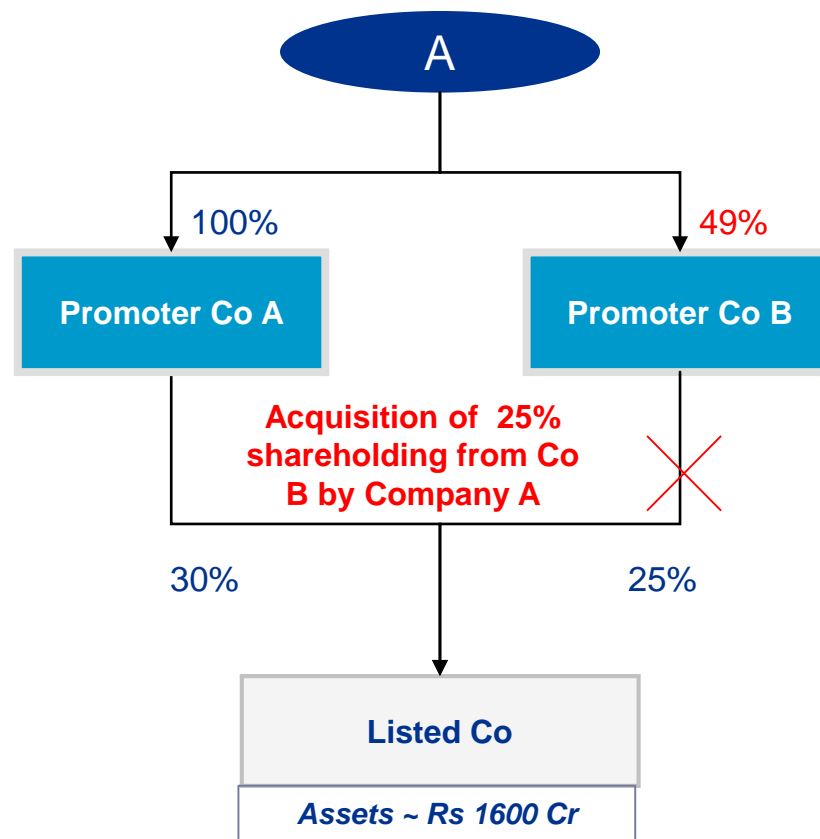

Does the above acquisition qualify for intra group exemption

Case Study - Acquisition of Business

4

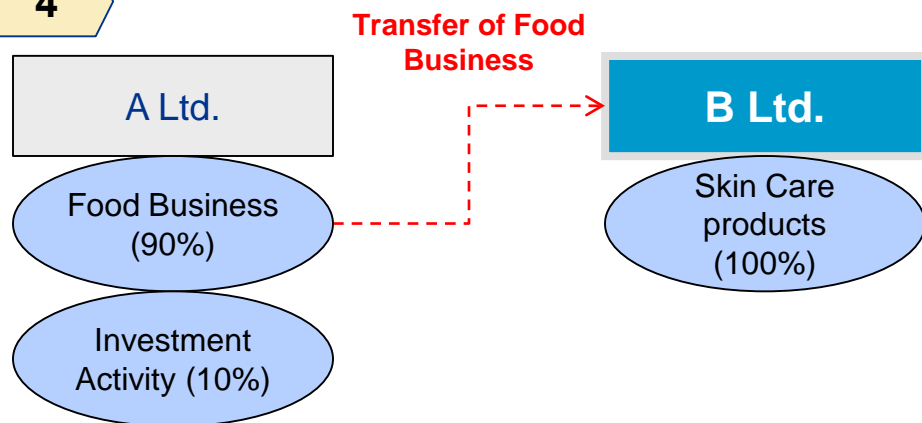

Transaction: Sale of Food Business of A Ltd. To B Ltd

Whether CCI approval required?

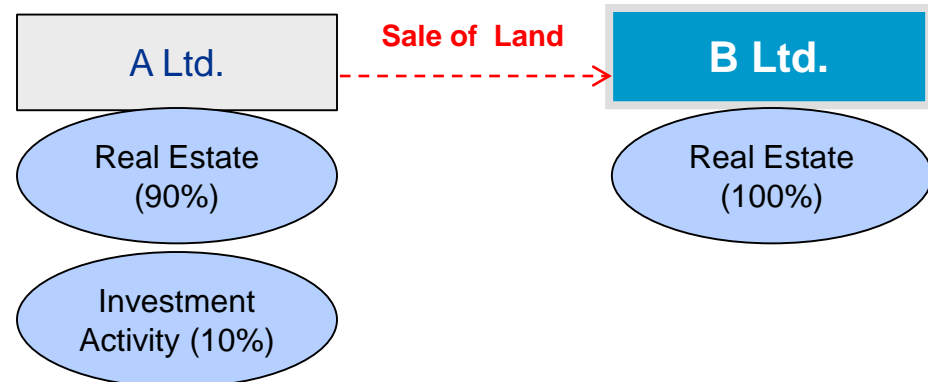

Transaction: Sale of Land by A Ltd. To B Ltd.

Whether CCI approval required?

Case Study - Buy-back of shares

5

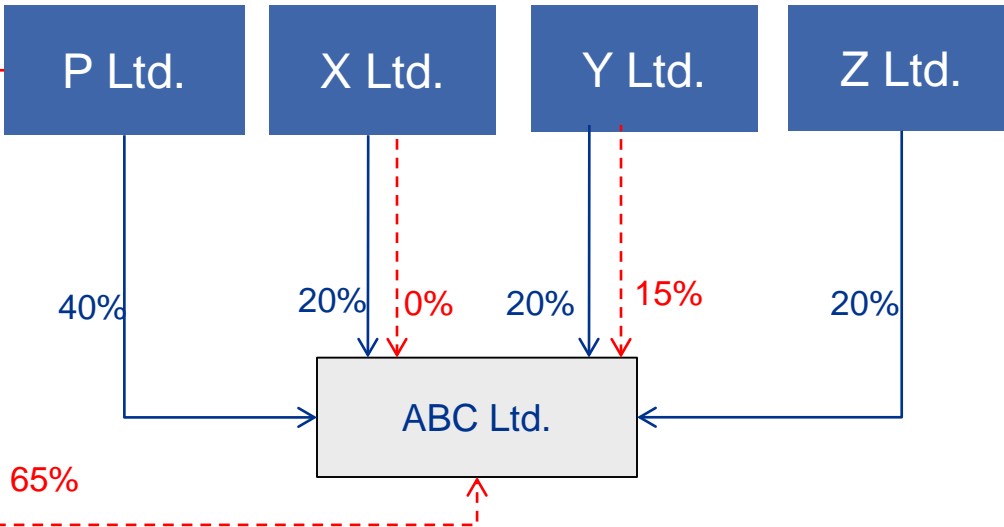

Transaction: Buyback of shares of ABC Ltd.

Facts:

- ABC Ltd. proposes to do a buyback of shares
- X Ltd. tenders 20% shares
- Y Ltd. tenders 5% shares
- Pursuant to buyback, P Ltd.'s stake in ABC Ltd goes beyond 50%

Whether CCI approval required?

Case Study - Transfer of business and acquisition of shares

6

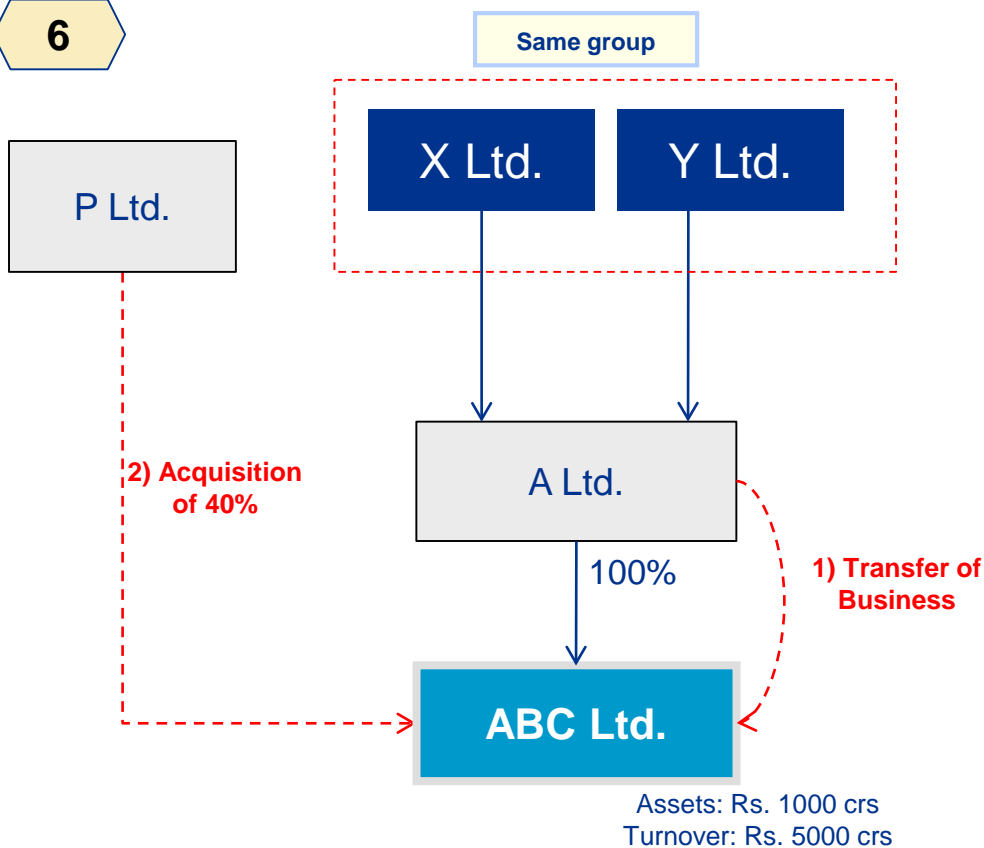

Transactions:

- 1) Transfer of Business by A to ABC Ltd.
- 2) Acquisition of 40% stake in ABC Ltd.

Whether CCI approval required for transfer of Business by A Ltd. to ABC Ltd. ?

Whether CCI approval required on acquisition of 40% stake in ABC Ltd.?

Whether CCI approval required if Venture Capital Fund is acquiring stake in ABC Ltd.?

Case Study - Merger

7

Whether exempt under Entry 9 of Schedule 1?

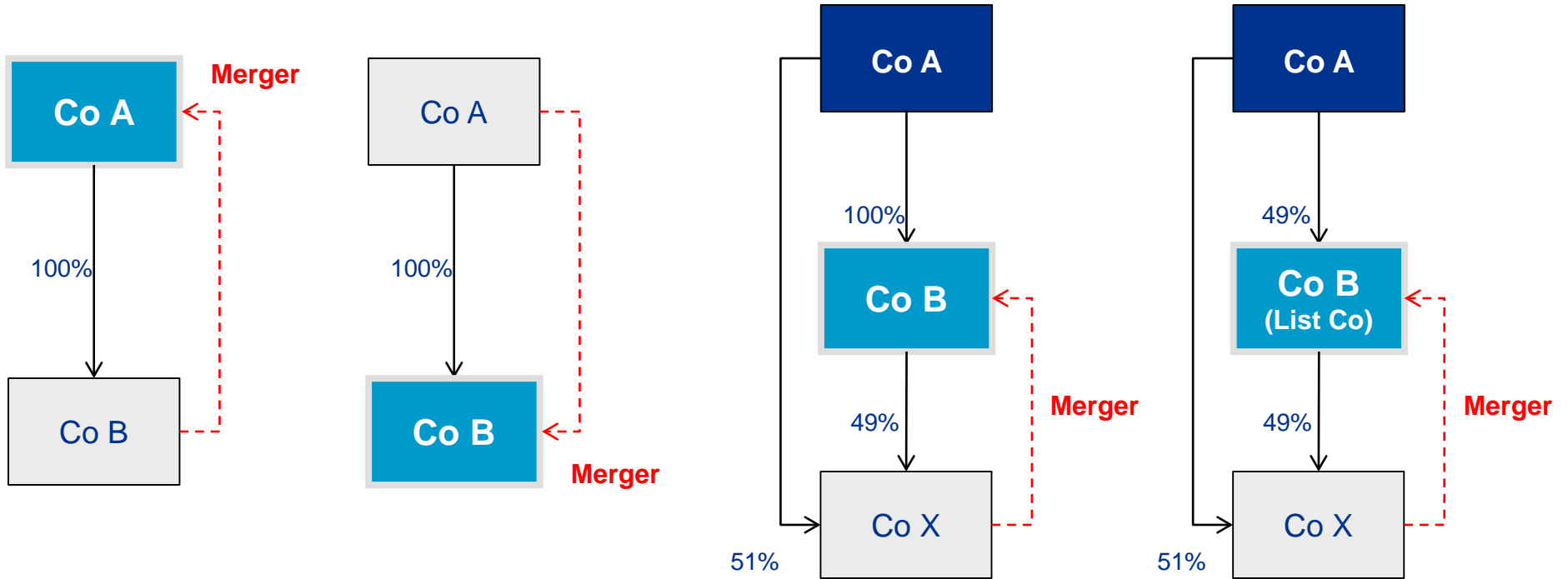

Case Study – Merger & Joint Control

8

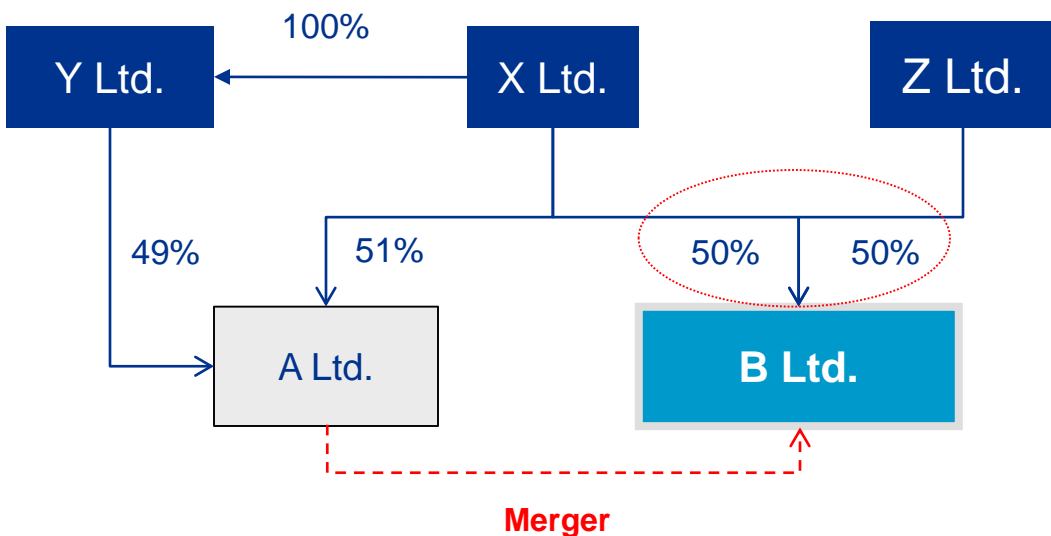

Transaction: A Ltd. to merge with B Ltd.

Facts

- Z Ltd. is not related to X Ltd or Y Ltd
- A Ltd. is part of X Ltd.

Whether CCI approval required for merger?

Meaning of Sole Control / Joint Control ?

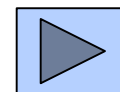

3

PE with veto rights

9

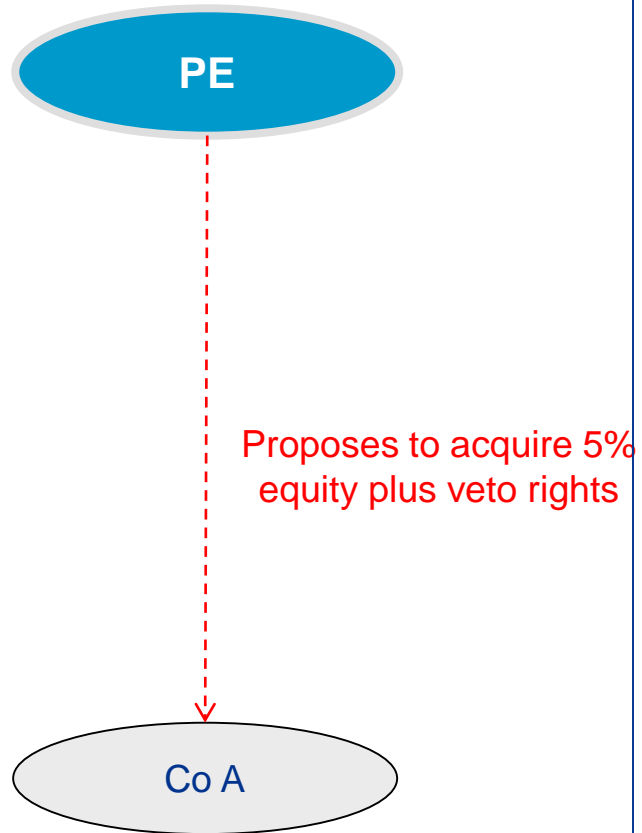

Would notice to CCI be required?

Exemptions under Section 6(4)/(5)

- Combination provisions are not applicable on:
 - Share subscription or financing facility or any acquisition by the following entities pursuant to any covenant of Loan agreement / Investment agreement
 - Public Financial Institution (PFI);
 - Foreign Institutional Investor (FII);
 - Bank; or
 - Venture Capital Fund (VCF)
 - Details of such acquisitions to be filed with the CCI within 7 days of the date of the acquisition ***along with Certified Copy of the Loan Agreement or Investment Agreement***
 - ***CCI has power to condone the delay in filling above notice in Form III***

Whether a notice needs to be filed at the time of entering into agreement???

Exemption for Banking Companies

Vide Notification SO 93(E) dated 8th January, 2013, the government has exempted a banking company in respect of which Central Government has issued a notification under Section 45 of Banking Regulation Act from the application of section 5 and 6 of the Act, in the public interest, for a period of 5 years from the date of publication of this notification in the Official Gazette

Prescribed Forms

Form	When to file	Information asked for	Filing fee
Form I	<ul style="list-style-type: none"> ▪ To be ordinarily filed for all transaction 	<p><u>Simplified form :</u></p> <p>Basic information about the parties, proposed combination, products etc</p>	Rs. 15 lakhs
Form II	<ul style="list-style-type: none"> ▪ may be filed at the option of parties preferably where- <ul style="list-style-type: none"> - Horizontal combination with more than 15% market share - Vertical combination with more than 25% market share ▪ CCI may also require parties to file Form II where it deems fit to form its prima facie opinion 	<p><u>Exhaustive form:</u></p> <p>Details including reports on viability of combination, information on market & product</p>	Rs. 50 lakhs
Form III	<ul style="list-style-type: none"> ▪ Post intimation - for acquisition by a FI, FII, Bank or VCF pursuant to covenant of loan/ investment agreement u/s. 6(4)/(5) 	Basic information about the parties, nature of acquisition etc.	No fees
Form IV	<ul style="list-style-type: none"> ▪ Publication of details if so ordered by CCI 	-	-

Combination Regulations – Filing Requirements

- **Notice to be filed by-**
 - In case of acquisition of control etc: by the acquirer
 - In case of enterprise is acquired without its consent: by the acquirer to the extent of information available. CCI may direct the target enterprise to furnish information
 - In case of merger / amalgamation: Jointly by the parties to the combination

- **Trigger event for filing notice** - Notice to be made within 30 days of the:
 - Approval of the proposed merger / amalgamation by the Board of Directors of the enterprises concerned
 - execution of any agreement or other document for the acquisition / acquiring of control

Combination Regulations – Filing Requirements

- **“Other document”** means any binding document conveying an agreement or decision to acquire control, shares, voting rights or assets:
 - If the acquisition is without consent, any document executed by the acquiring enterprise (by whatever name called) conveying a decision to acquire control, shares or voting rights shall be the ‘other document’
 - *Where a public announcement has been made in terms of the Securities and Exchange Board of India (Substantial Acquisition of Shares and Takeovers) Regulations, 2011, for acquisition of shares, voting rights or control, such public announcement shall be deemed to be the “other document”*

[Inserted pursuant to [CCI (Procedure in regard to the transaction of business relating to combinations) Amendment Regulations, 2016, notified on 7th January, 2016]

Thank You

C.A. Devarsh Patel