

IFSC GIFT City

Ship Leasing framework & allied laws

Mr. Kunal Gandhi

WIRC (Mumbai)

17 June 2023



Regulatory framework – Background

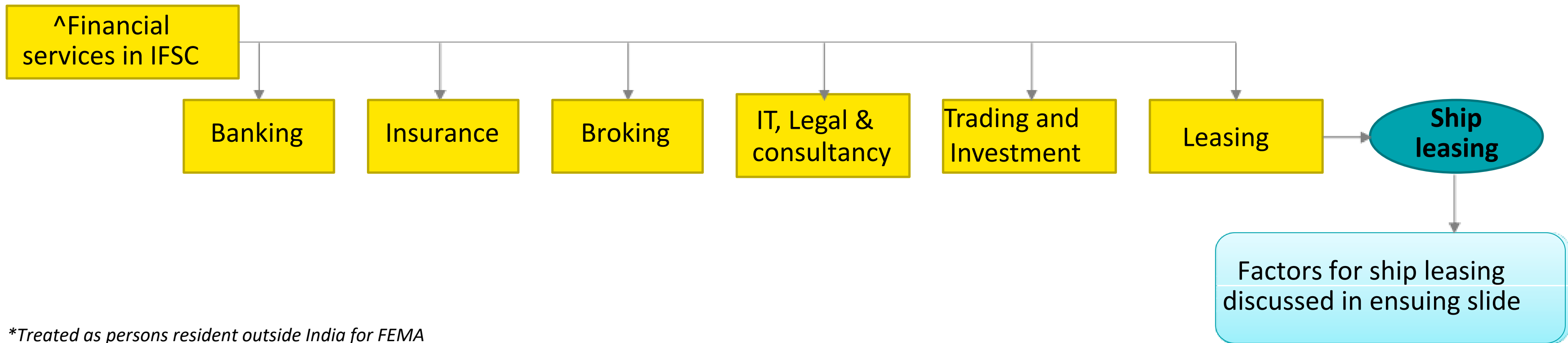
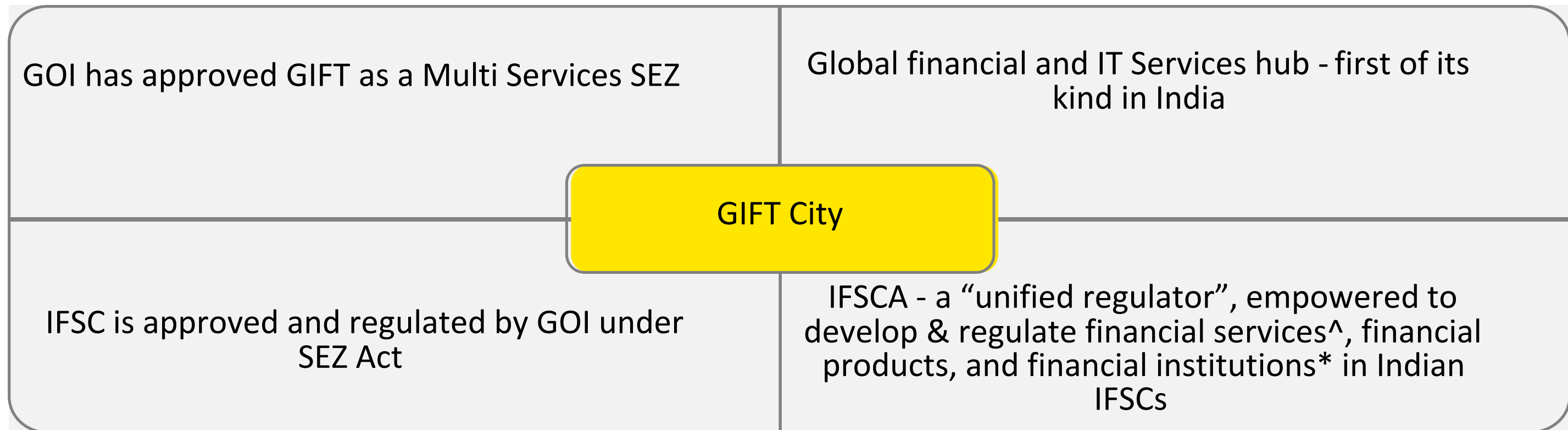

*Treated as persons resident outside India for FEMA

Regulatory framework – permissible activities, commercial substance and legal form

Ship leasing framework* (including circular) issued notifying permissible activities/ arrangement, commercial substance required of entity desirous of operating through IFSC

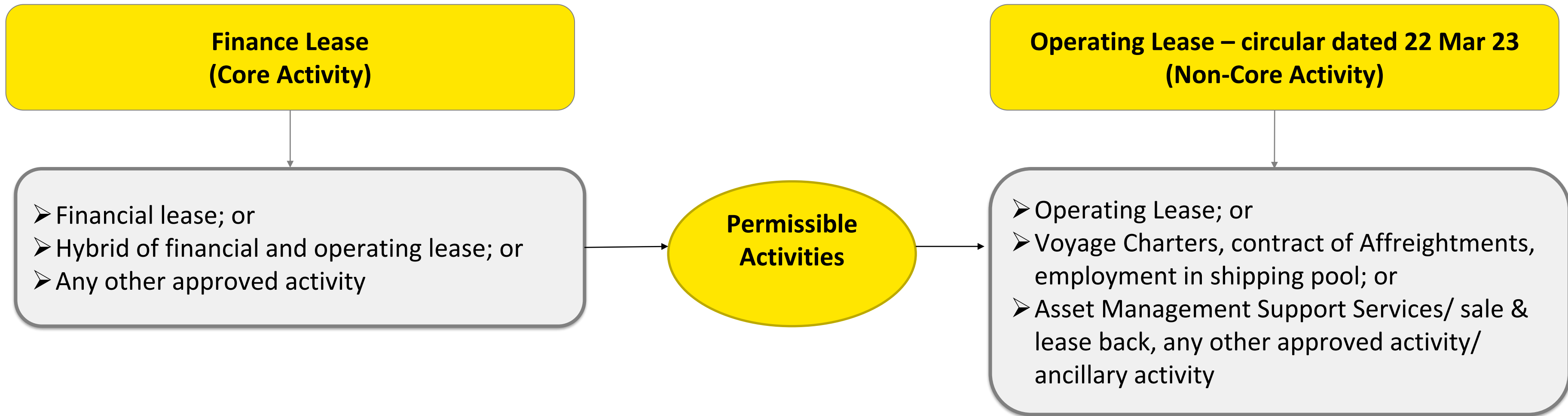

Commercial substance to be demonstrated like Promoters to be Financial Action Task Force compliant jurisdiction, resources to be deployed in IFSC, obtain office space, etc

Entity in IFSC can be setup in form of company, Limited Liability Partnership, Trust, Branch, etc

Ensuing slide captures key tax benefits in India for operating through/with IFSC

IFSC – key tax benefits / incentives

1

Tax Holiday to International Financial Service Center unit:

- ▶ Profits deductible for 10 consecutive years out of first 15 years of operation
- ▶ Capital gains from transfer of ship by an IFSC unit deductible (subject to certain conditions)

2

Concessional Minimum Alternative Tax (MAT) / Alternative Minimum Tax (AMT) rate:

- ▶ Concessional MAT / AMT @ 9% applicable to IFSC unit deriving its income solely in convertible foreign exchange
- ▶ MAT not applicable, if opted for new Corporate Tax Regime i.e. tax rate of 25.17%

3

Tonnage tax scheme (TTS):

Vide recent tax amendment, relaxed Tonnage tax scheme allowing IFSC units to apply under TTS post tax holiday period

4

Exemption to Non-resident Lessor:

Non-resident income by way of royalty or interest, on account of lease of a “ship” exempt *provided unit has commenced operations on or before 31 March 2024*

5

Concessional tax rate on dividends

Dividends paid to non-residents by a unit in International Financial Service Center taxable at lower tax rate of 10%

Case study 1 – Lease income

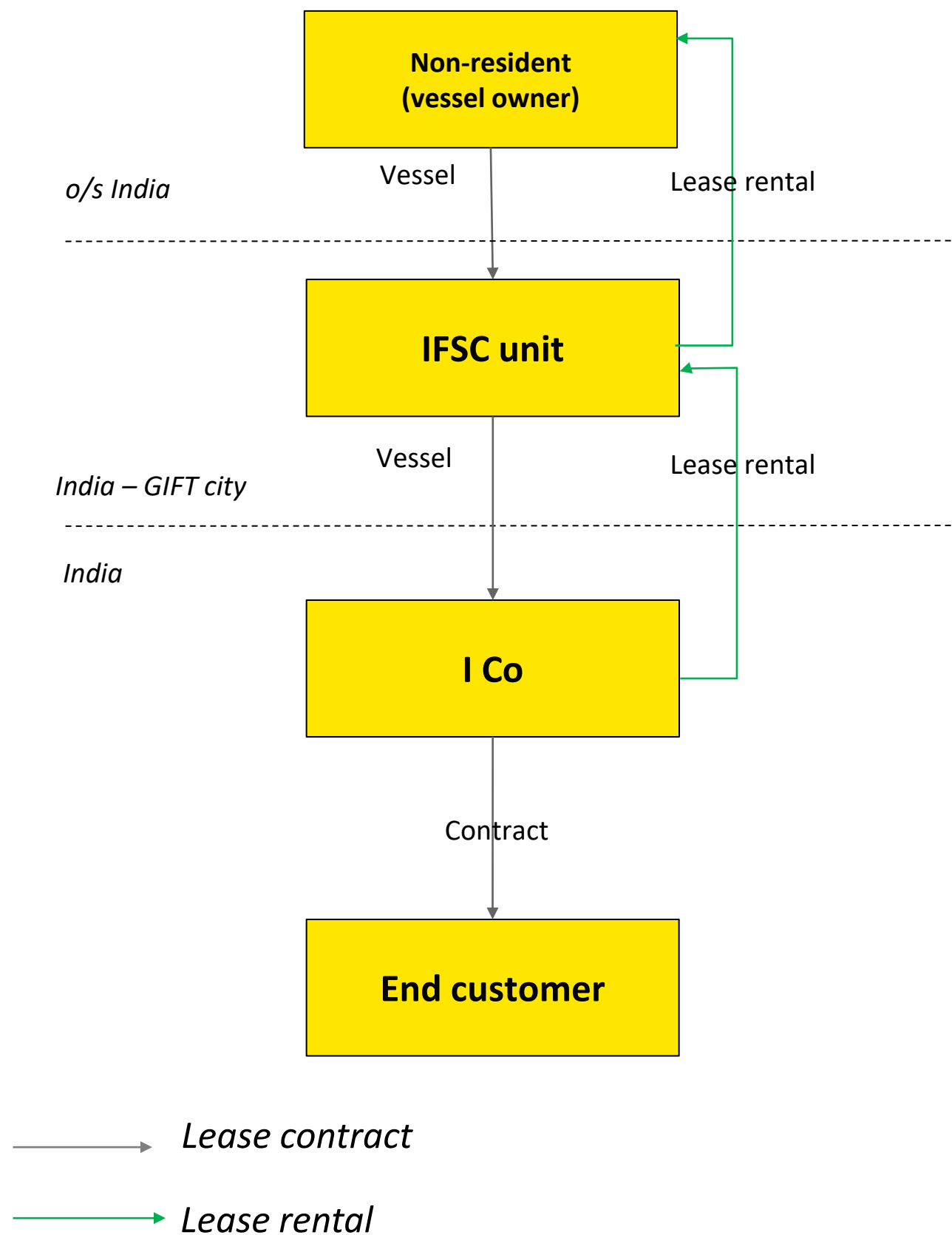

Mechanics

- ▶ I Co to provide the vessel in India to end customer
- ▶ Non-resident (vessel owner) creates IFSC unit in GIFT city & leases vessel to IFSC on BBC
- ▶ IFSC unit, in turn, leases vessel on BBC to I Co
- ▶ I Co hires requisite manpower & executes contract with end customer

Tax implications in the hands of IFSC GIFT City Unit & Non-resident?

Case study 2 – Sale of vessel

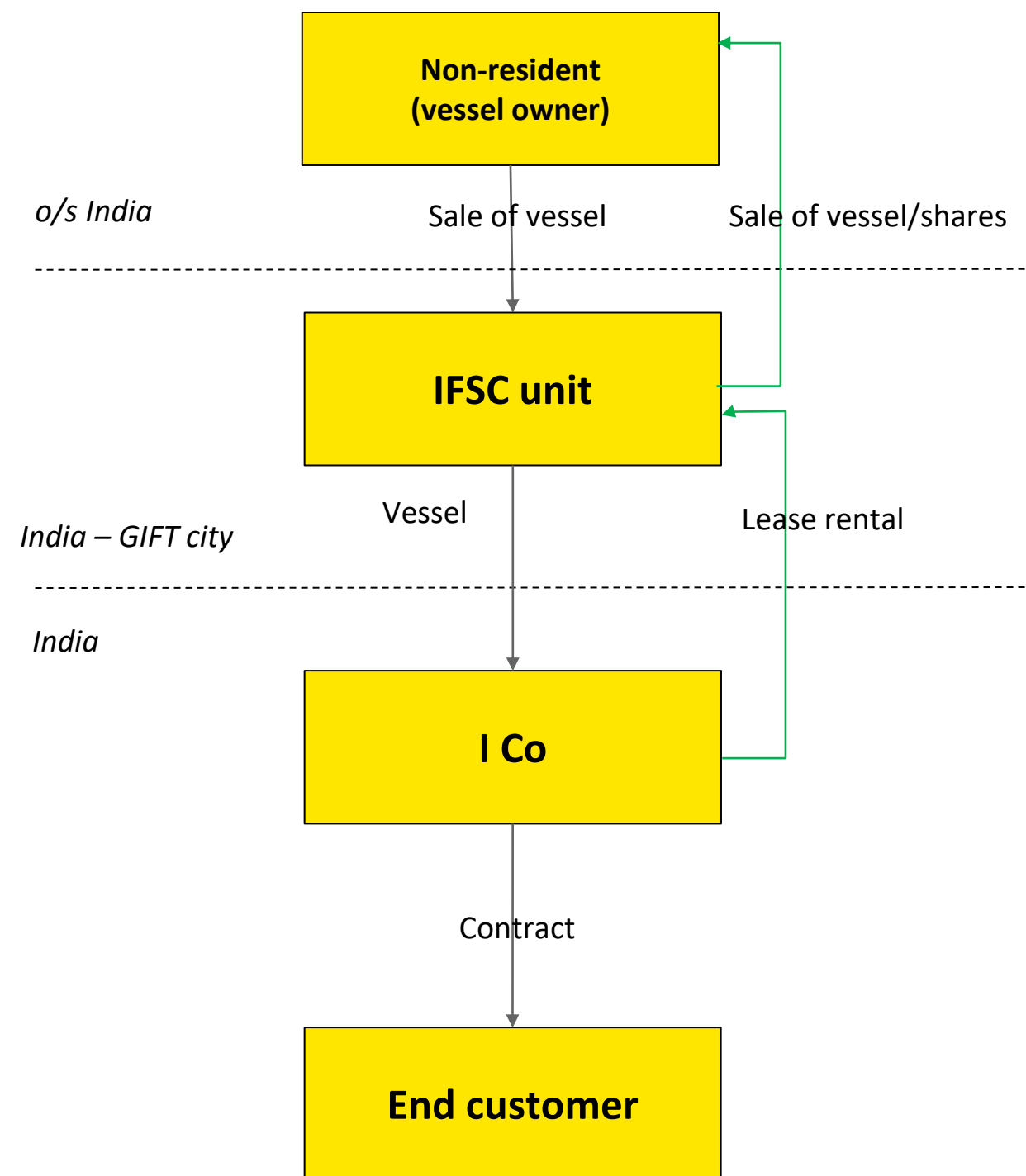

Mechanics

- ▶ I Co to provide vessel to customer
- ▶ Non-resident creates IFSC unit in GIFT city & sells vessel to IFSC unit
- ▶ IFSC unit leases vessel on BBC to I Co
- ▶ I Co hires requisite manpower & executes contract with end customer
- ▶ IFSC resells vessel on completion of contract

Tax implications in the hands of IFSC GIFT City Unit & Non-resident?



Annexures

Annexure 1 – Regulatory framework – key terms

Term	Definition
Operating Lease	Activity of leasing such that it does not transfer substantially all risks and rewards incidental to ownership of asset involved
Finance lease	Activity of leasing such that it transfers substantially all risks and rewards incidental to ownership of asset involved
Lessor	An entity registered with IFSCA as a Finance Company or Finance Unit, and Engaged in business of providing ships or ocean vessel and engines of ship or ocean vessels, or any other part thereof under an operating lease, financial lease and/or a hybrid of financial and operating lease and /or, any other related activity as may be specified by the Authority
Ship	Shall include any watercraft, used or capable of being used in navigation by its own propulsion, in, above, or under the water but does not include fishing or sailing watercraft
Ocean vessel	Include every description of watercraft used or capable of being used in marine environment such as ship, boat, sailing vessel, fishing vessel, submersible, semi-submersible, hydrofoils, non-displacement crafts, amphibious crafts, wing-in-ground crafts, pleasure crafts, barges, lighters, MODU, MOU, or of any other description, or any part thereof, and shall include inland water vessels and coasting vessels, but does not include fishing or sailing watercraft



Annexure 2 – Regulatory framework – features

Particulars	Finance lease (core activities)	Operating lease (non-core activities)
Capital requirement	USD 3 million or equivalent	USD 0.2 million or equivalent
Fees	(i) Application Fee: \$ 1,000 (one time) (ii) Registration Fee: \$ 12,500 (one time) (iii) Annual Fee: \$ 12,500 (second year onwards)	(i) Application Fee: \$ 1,000 (one time) (ii) Registration Fee: \$ 12,500 (one time) (iii) Annual Fee: \$ 5,000 (second year onwards)
Currency for conduct of business	<ul style="list-style-type: none"> ▶ Transactions by lessor in freely convertible foreign currency only ▶ Lessor may defray administrative expenses in INR by maintaining a separate INR account 	
Maintenance of books, records & documents	The books of accounts and financial information shall be maintained in any freely convertible currency	
Submission of report / information	<ul style="list-style-type: none"> ▶ Lessor shall furnish few information to IFSCA within 15 days from finalization of annual financial statement like (i) audited annual financial statement; (ii) confirmation of compliance with capital requirement, etc., ▶ Lessor to submit the financial information, expressed in USD, to IFSCA, unless otherwise specified 	





THANKYOU!

Disclaimer: All comments are personal and do not represent the views of an organisation. The speaker disclaims any liability arising from comments included in the presentation which are intended only for general guidance. The comments in the presentation in no manner shall be used as a substitute of professional advice. Before acting on any matters contained herein, reference should be made to the Act, DTAA, amendments, CBDT Circulars/notifications issued from time to time.